

# BS|ACOUSTICS

## Ara Kit



User Manual

---

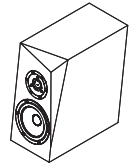

### Technical specification :

Frequency range	: 45-25000 Hz +/-3 dB
Sensitivity (2.83V / 1m)	: 87 dB
Nominal impedance	: 4
Max SPL	: 105 dB
Recommended amplifier	: 40-150 W
Cross-over frequency	: 3 kHz
Speaker type	: 2-way
Enclosure type	: Bass reflex
Port tuning frequency	: 36.5 Hz

### Drive Units:

- High frequency driver : SATORI TW29R (29 mm soft ring dome)
- Low frequency drivers : 6½" SATORI MW16P-4 (advanced midwoofer)

### Cabinet:

15mm MDF

Dimensions (H x W x D): 391 x 190 x 388 mm / 15.4 x 7.48 x 15.27 inch

### Net weight (pair):

- Cabinet only : 8.06 kg / 17.77 lb
- Full assembly : 9.6 kg / 21.16 lb

### Special Features:

- Advanced high-end drivers.
- Facets on top of cabinet for reduced high frequency diffraction.
- Inclined baffle for correct time alignment of drivers  
(allowing for simpler cross-over design)
- Wedge shaped inner rear walls behind midwoofer for reduced direct reflection
- Internal bracing to reduce and distribute cabinet vibrations and hence lower sound coloration
- Solid single-wiring binding posts

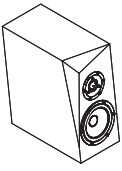

# Frequency response

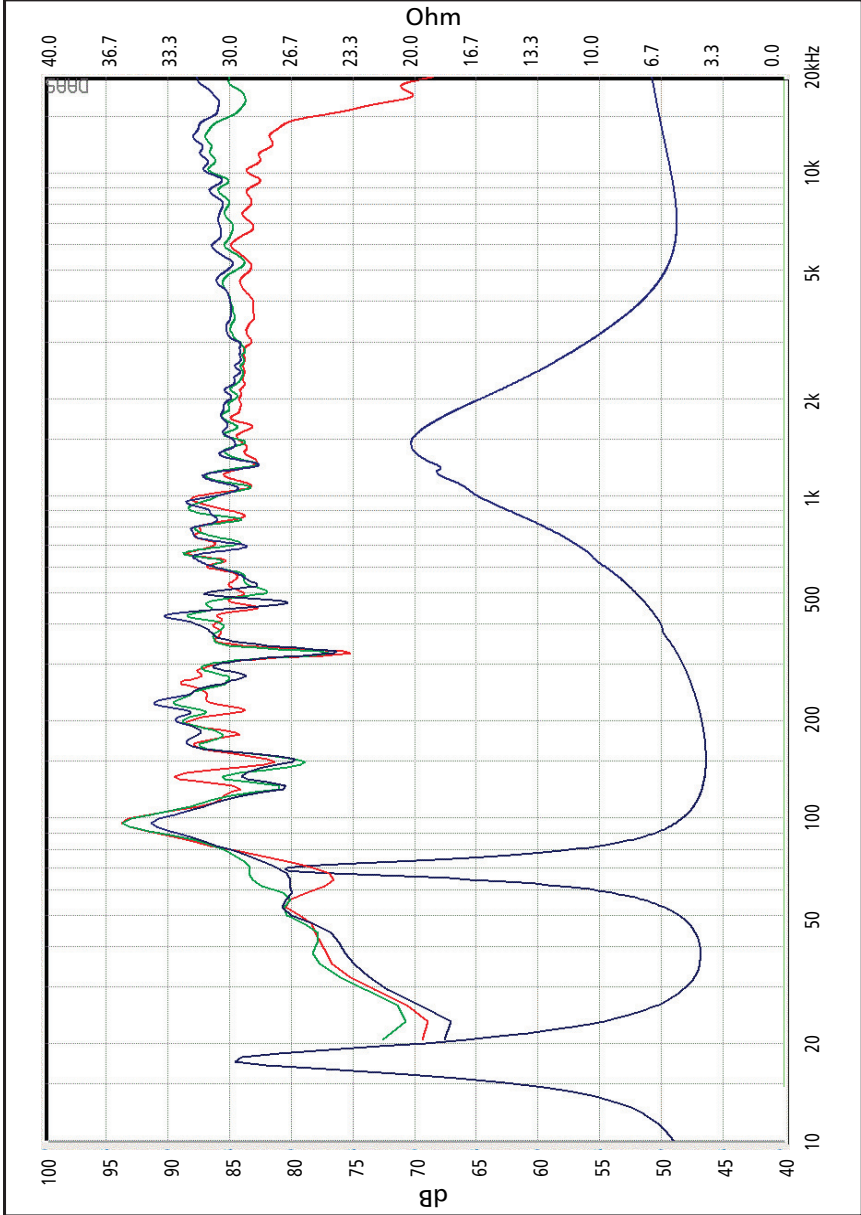

Response Curve :  
— (Blue) : on axis  
— (Green) : 15° off-axis  
— (Red) : 30° off-axis

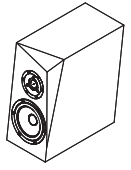

## Mechanical drawing (size in mm)

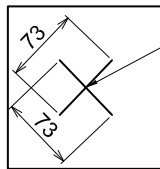
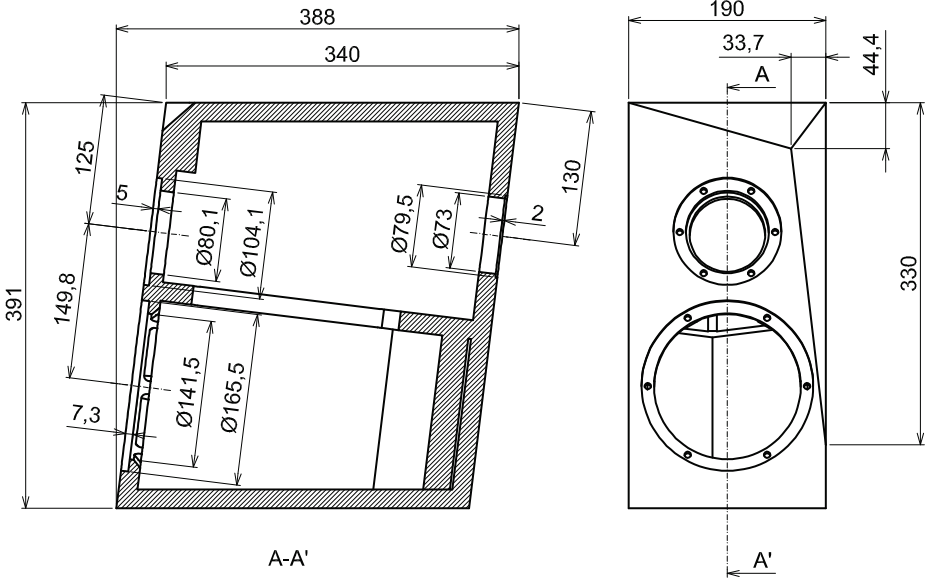

X-CUT  
FOR  
PAPER PORT

X-CUT EXAMPLE

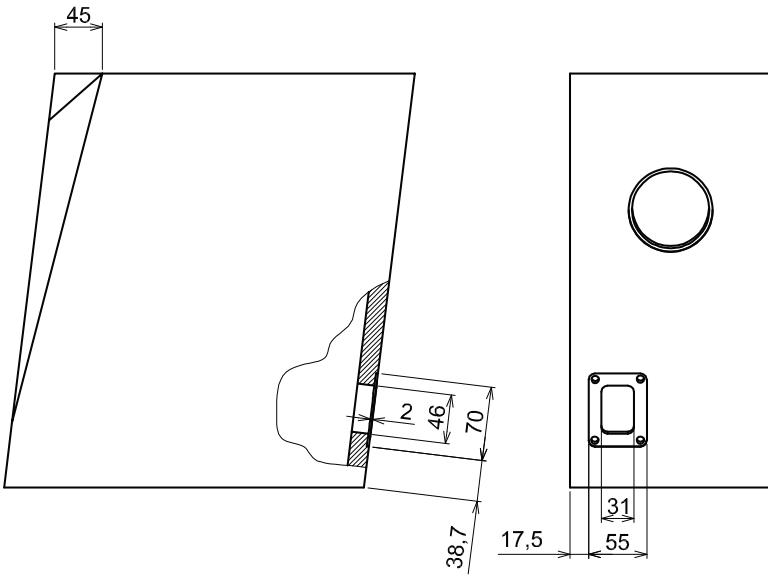
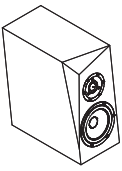

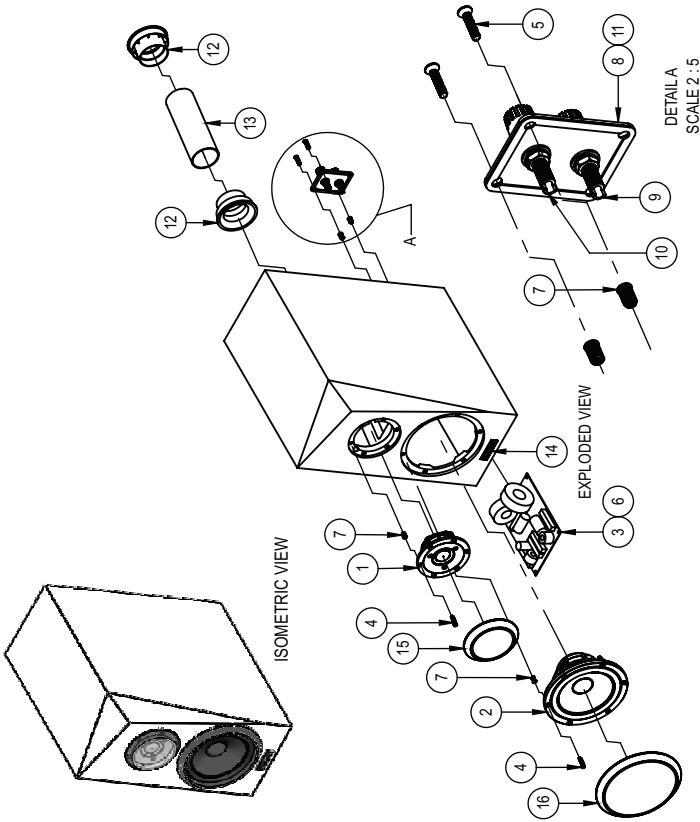
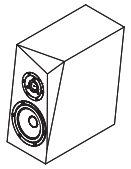

NO.	PART NUMBER	QTY.
1	SATORI TW29R (Sold separately)	1
2	6½" SATORI MW16P-4 (Sold separately)	1
3	Ara Kit Crossover (Sold separately)	1
4	Hex Socket Screw 4x20mm (For driver)	12
5	Countersunk Screw 4X20mm (For terminal plate)	4
6	Wood Screw 4x16mm (From kit crossover)	6
7	Insert Nut IM4 (Installed)	16
8	Stainless Steel Terminal Panel	1
9	Binding Post (-) (Black)	1
10	Binding Post (+) (Red)	1
11	Seal Gasket (For terminal plate)	1
12	Port flare d:50mm (Installed on cabinet)	2
13	Paper tube d:50mm L:160mm (Installed on cabinet)	1
14	Name Plate	1
15	Grille for tweeter	1
16	Grille for woofer	1
17	Damping Material (See out pattern)	1

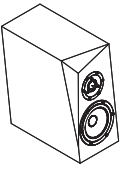

### Damping Material Cut Pattern (Size in mm)

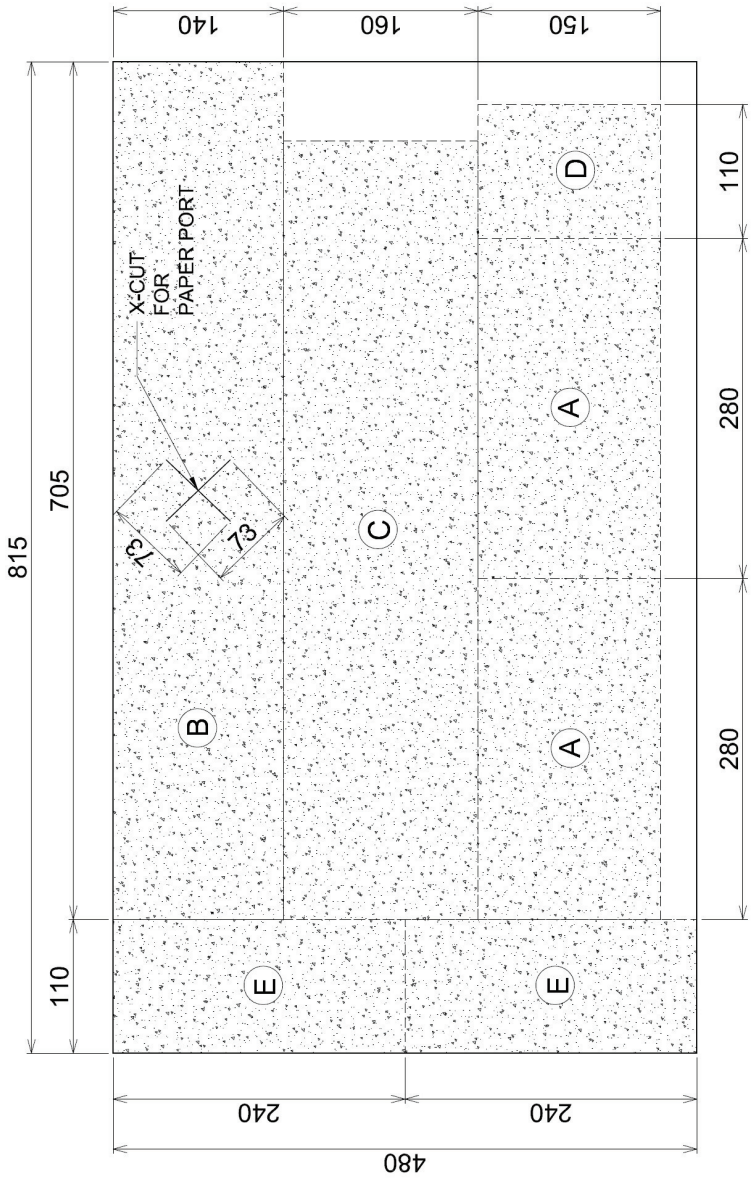

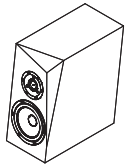

## Damping material position (size in mm)

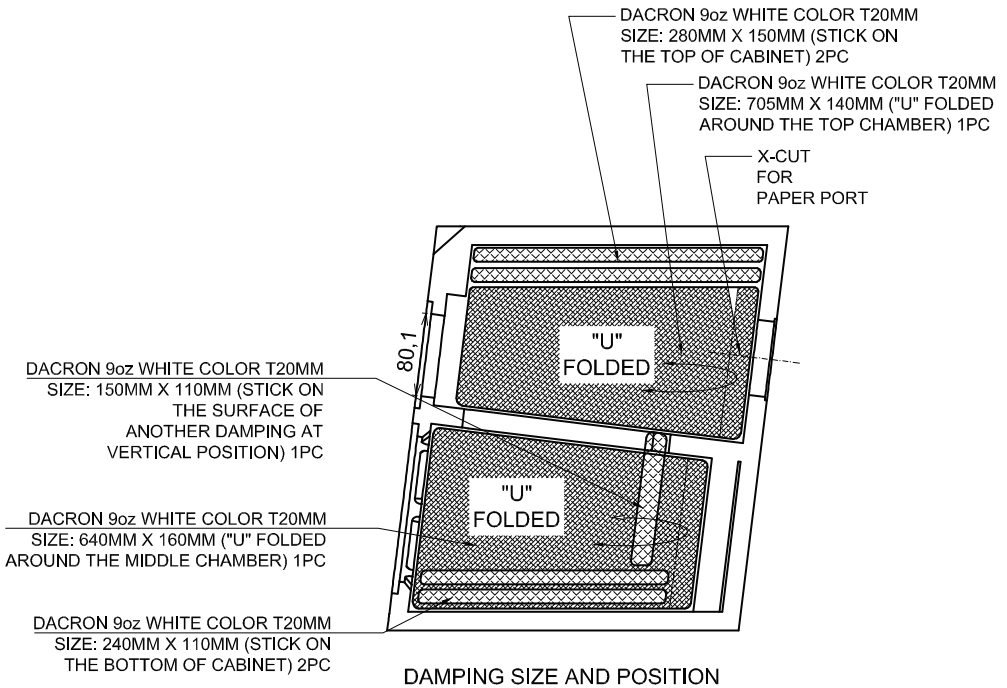



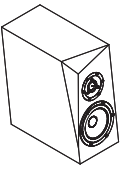

### Crossover Schematic

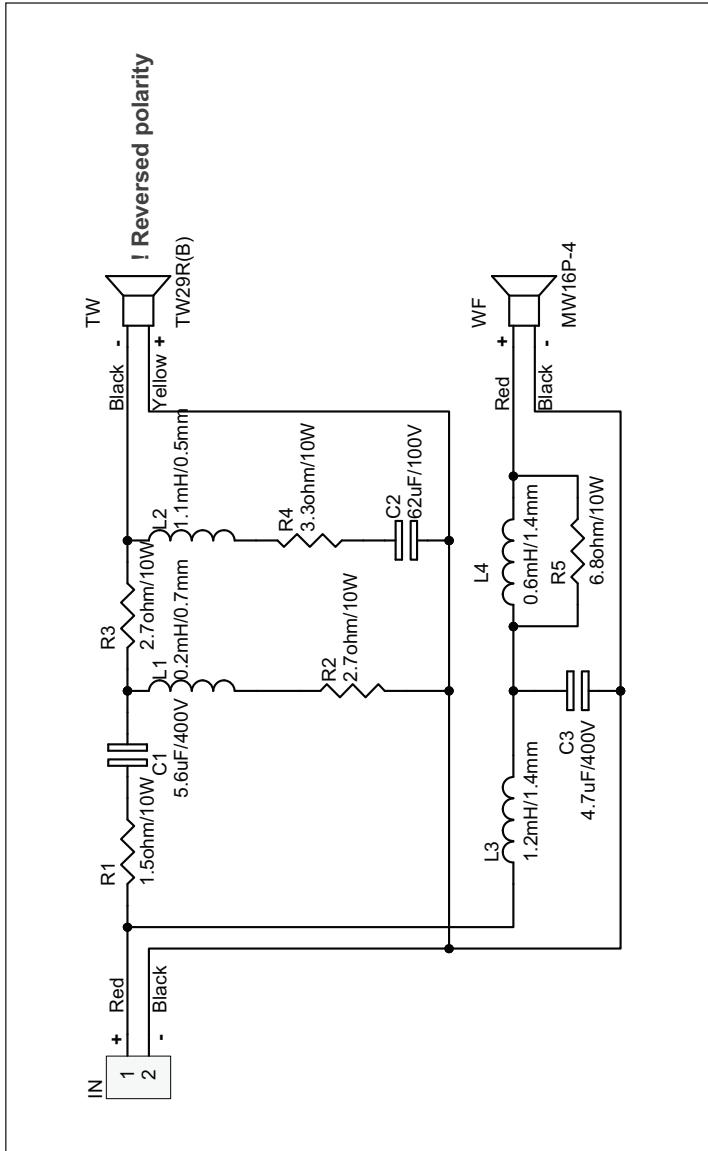

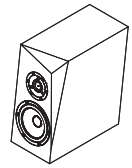

## Assembling instruction

### Part list (each cabinet):

- High frequency driver Satori TW29R (sold separately).....	1 pc
- Low frequency drivers 6½" Satori MW16P-4 (sold separately) .....	1 pc
- Ara kit crossover (sold separately) .....	1 pc
- Hex socket screw M4 x 20mm (for drivers) .....	12 pcs
- Countersunk screw M4 x 20mm (for terminal plate) .....	4 pcs
- Wood screw 4 x 16 mm for crossover (from kit crossover) .....	6 pcs
- Insert nut M4 (installed on cabinet) .....	16 pcs
- Stainless Terminal plate .....	1 pc
- Binding post .....	1 pair
- Seal gasket (for terminal plate) .....	1 pc
- Port flare (installed on cabinet) .....	1 pc
- Port paper tube (installed on cabinet) .....	1 pc
- Damping .....	1 pc
- Name plate .....	1 pc
- Tweeter grill .....	1 pc
- Woofer grill .....	1 pc

### Tools needed:

- Hex key 3mm size (for driver screw)
- Hex key 2.5mm size (for terminal plate screw)
- Philips screwdriver no. 2 (for crossover screw)
- Soldering iron + tin (for soldering input wire to terminal)
- Hot melt glue gun (for attaching the damping and sealing the wire hole)

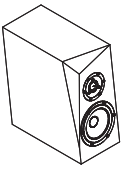

1. Take out the cabinet from the packaging and take out the raw damping material from the cabinet



2. Cut the raw damping material to 7 pcs of damping according to the cutting pattern diagram

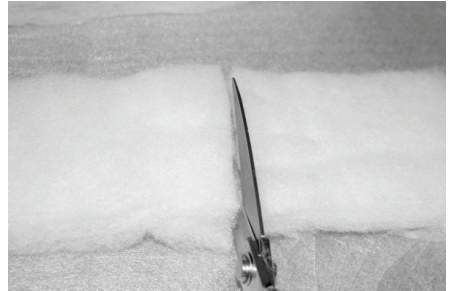

3. Put the crossover on top of the bottom panel, place the two big inductor side towards the rear terminal side

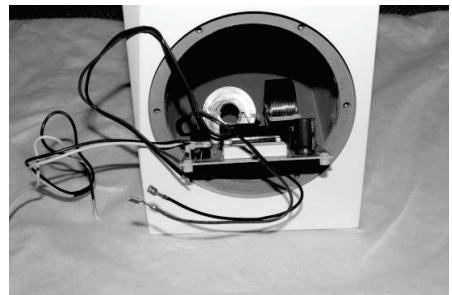

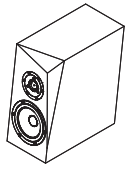

4. Fasten the crossover by tightening all 6 screws



5. Pass the input wire through hole in the rear panel of the cabinet

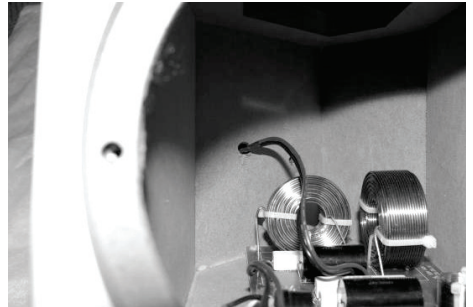

6. Seal the cable hole with hot melt glue

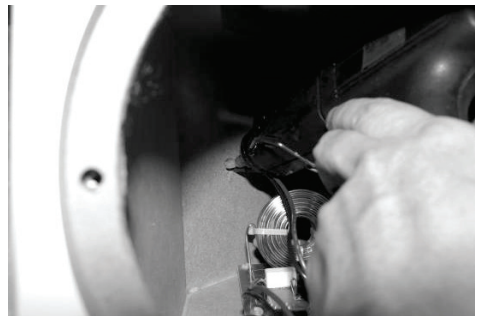

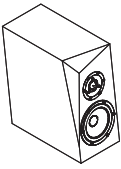

7. Pull the tweeter cable through the hole in cabinet bracing



8. Place each damping part into the cabinet according to position diagram. Add a bit of glue if needed to hold the damping in place

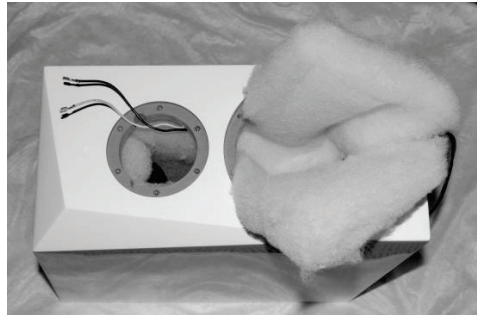

9. Pull out the input cable through the terminal hole then solder it to the binding post terminal



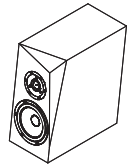

10. Mount the terminal panel into the terminal hole at the back side

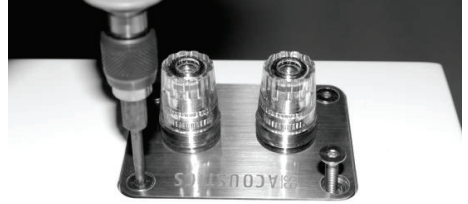

11. Hook up the cable to the tweeter and woofer terminal



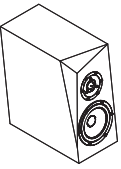

12. Mount the driver to the cabinet and fasten the screws

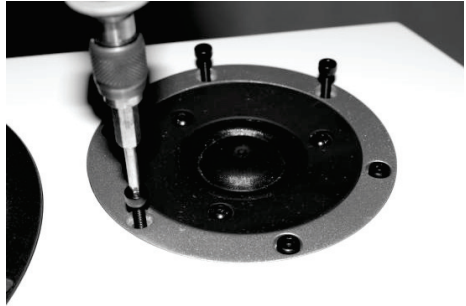

**Find Us On**



[www.sbacoustics.com](http://www.sbacoustics.com)

---