

FT96H

Features

- * FT96H is the horn super tweeter has the high performance magnetic circuit using alnico magnet.
- * Equipped with the aluminum alloy horn + light weight ring diaphragm.
- * Mountable on the speaker baffle board.
- * Recommendable for the combination with FE-Esigma series fullrange units and as the super tweeter of the multiple way speaker systems.



Specifications & Thiele/Small Parameters

Impedance	: 8Ω
Reproduction Frequency Response	: 4kHz to 33kHz
Sound Pressure Level	: 100dB/W (1m)
Rated Input	: 50W (music)
Cutoff Frequency	: <3.9kHz
Recommended Crossover Frequency	: <8.0kHz
Magnet Material	: Alnico magnet
Magnet Weight	: 34g / 0.07lb
Net Weight	: 600g / 1.32lb

Frequency Response / Impedance

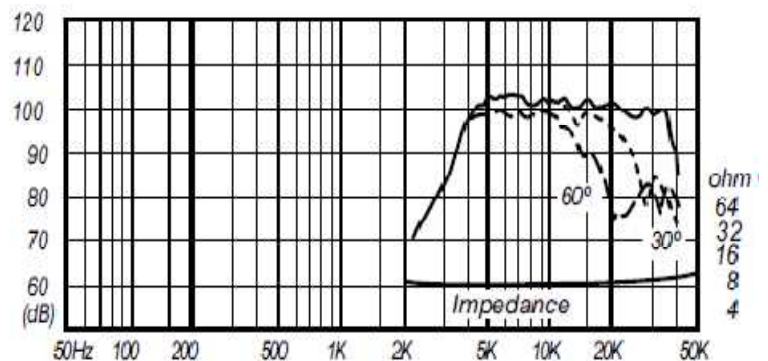

Configuration Example

FE208E sigma + FT96H

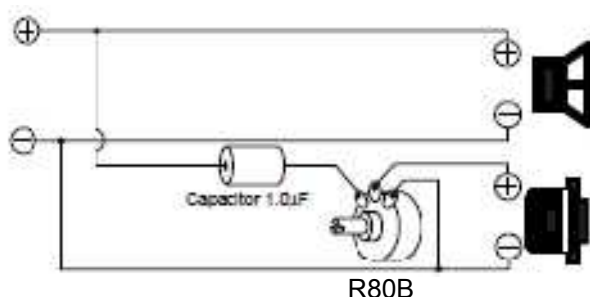

Dimensions

/ Mounting Information

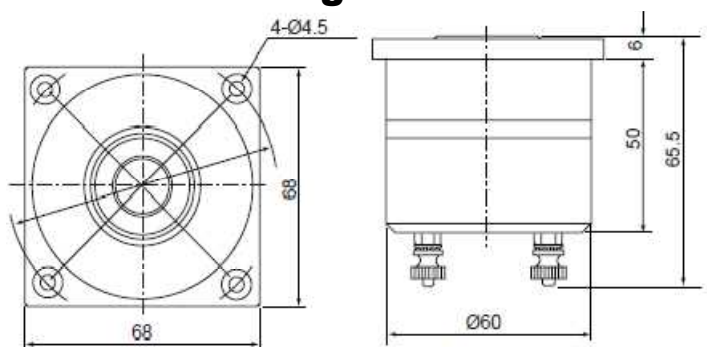

Width / Height	: 68mm / 2.67"
Baffle Hole Diameter	: 61mm / 2.4"
Depth	: 66mm / 2.59" or more